



## Product Specification

# Wave Design Switch Panel with Circuit Breakers

SP1216P (6 Positions)

SP1216PW (6P with PVC Covers)

## Product Features:

- 12V DC Illuminated (LED) rocker switches
- Pre-wired with resettable circuit breakers
- Ultra shallow mounting depth (~45mm)
- 28 assorted label stickers included

## Product Specifications:

Material:	Wave shaped plastic (ABS)
Circuit Protection:	Push Reset Circuit Breakers
Ratings:	DC 12V Maximum Cumulative Amp: 35 A
Panel Depth:	45 mm
Dimensions:	100 x 160 mm
Mounting Dimensions:	77 x 148 mm
Notes:	

## Mounting Template

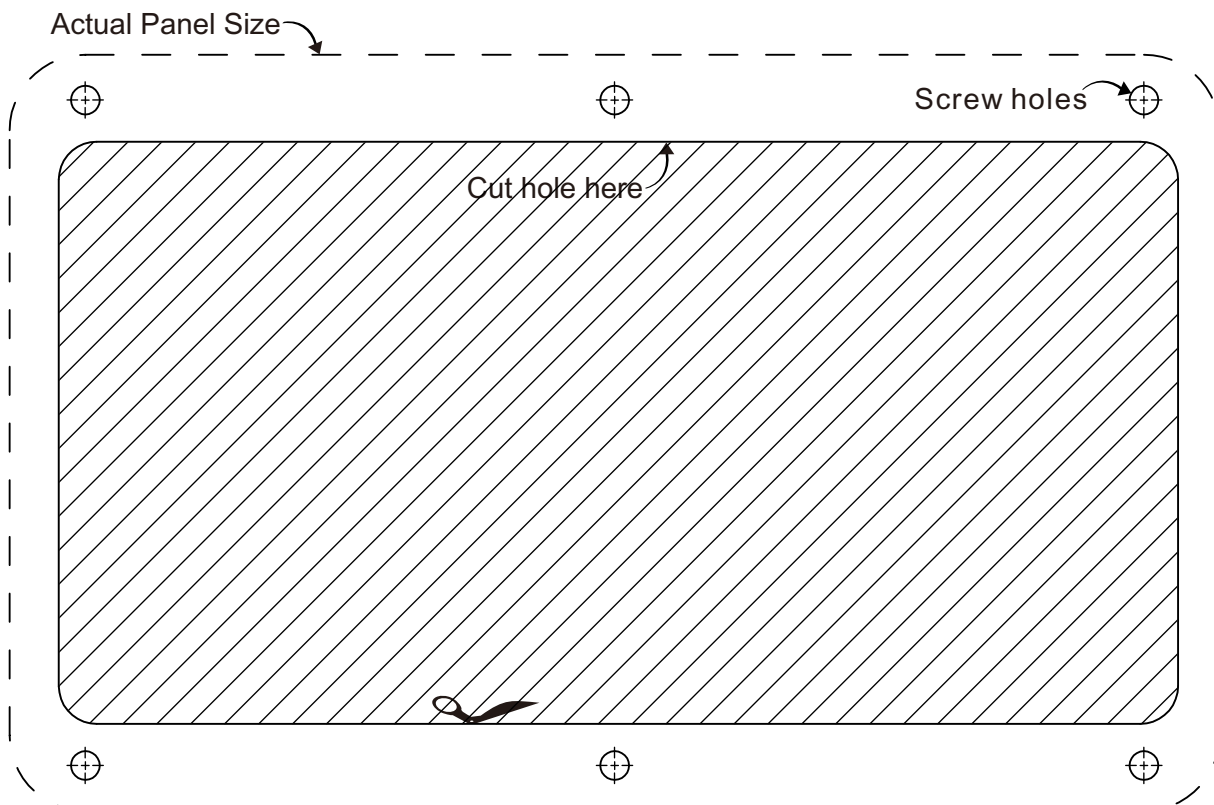

SP1216P

## Installation Instructions

1. Disconnect all power (AC & DC).
2. Cut opening for mounting location using the template provided.
3. Connect the positive wire (red) to the DC power source (the batteries) and the LED negative feed wire (black) to a DC negative bus bar.
4. Connect the devices to the load (middle) terminals of the switches using the included .205 quick terminals. Apply desirable labels to the recessed area at corresponding branches.
5. Mount the switch panel with the included self-tapping screws.
6. Reconnect all the AC & DC powers. Turn on and off all branch circuits to check if the panel works normally.

## Wiring Diagram

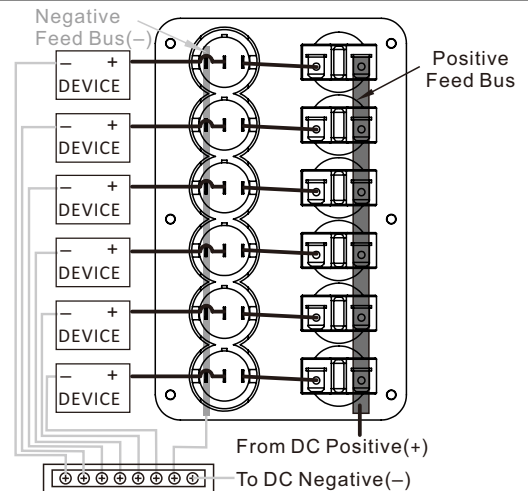

This template is provided to help you install the switch panel correctly. Cut out template and trace onto the dashboard. Then drill a hole at the shielded area.